



Watering the Life



Watering the Life

AQUA SMART 45

Instructions



www.aquastrong.it

24 months
≡ **GUARANTEE** ≡

CONTENTS

1. Installing the product	
1.1 Location	1
1.2 System sizing	1
1.3 Piping connection	2-5
2. Starting up the product	
2.1 Priming the pump	6
2.2 Starting up the pump	6
2.3 set the correct pressure	6-7
3. Identification	
3.1 Nameplate	8
4. Notice for use on the operating controlling panel	9
4.1 1 Duty & 1 Assistant Function Introduction	10-11
5. Error report warning light instructions	12-13
6. Taking the product out of operation	13
7. Warranty of product	14
8. Easy worn parts	15



Read this document and the quick guide before installing the product. Installation and operation must comply with local regulations and accepted codes of good practice.

Notice: Please read this instruction manual carefully before using this product.



The company will not be liable for any failures and losses caused by failure to observe the precautions specified in this manual. The relevant materials, illustrations and specifications in this manual are based on the latest information obtained at the time of publication. Due to the continuous updating of products, if there are discrepancies between the nameplate parameters and this manual, please kind refer to the nameplate.

1. Installing the product

1.1 Location

The pump can be installed indoors or outdoors, but it must not be exposed to frost.

We recommend that you install the pump near a drain or in a drip tray connected to a drain in order to lead away possible condensation from cold surfaces.

1.1.1 Minimum space

The pump requires a minimum space of 620 x 400 x 530 mm

Even though the pump does not require much space, we recommend that you leave enough space for service and maintenance access.

1.1.2 Installing the product in frosty environment

Protect the pump from freezing if it is to be installed outdoors where frost may occur.

1.2 System sizing

The pump is factory-set to 3 bar (44 psi) outlet pressure which can be adjusted according to the system in which it is incorporated.

The tank pre-charge pressure is 1.25 bar (18 psi).

In case of suction lift of more than 6 meters, the pipe resistance on the outlet side must be at least 2 meters water column or 3 psi at any given flow in order to obtain optimum operation.

1.3 Piping connection

- ! Make sure that the pump is not stressed by the piping system.
(flexible hose strongly recommend)
- ! Always loosen and tighten the union nuts on the inlet and outlet ports by hand.
Damage to the inlet and outlet parts increases the risk of leakage.

1. Turn the union nuts by hand to loosen the inlet and outlet ports.
2. Seal the pipe fittings with thread sealing tape.
3. Carefully screw the inlet and outlet connections to the pipe fittings using a pipe wrench or similar tool. Keep the union nut on the pipe fitting if you have removed it from the pump.
4. Fasten the connections to the inlet and outlet. Hold the connection with one hand and tighten the union nut with the other hand.

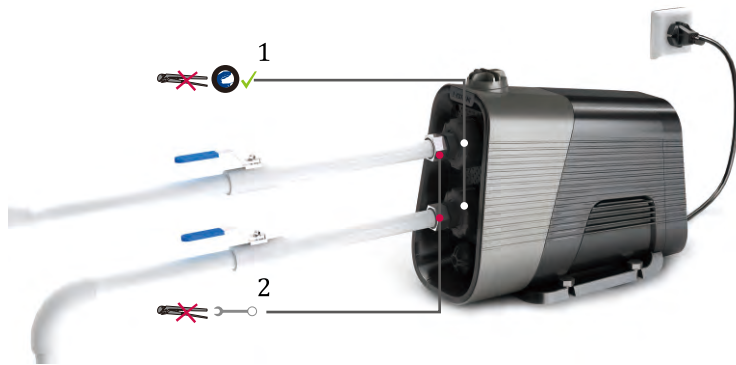

How to fit the connections

Pos.	Description
1	Inlet and outlet port
2	Union nut

- ! We recommend to follow the installation examples

1.3.1 Mains water pressure boosting

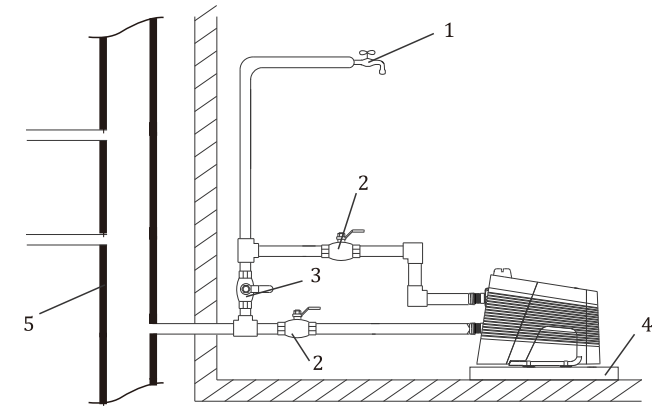

Mains water pressure boosting

Pos.	Description
1	Highest tapping point
2	Ball valve
3	Gate valve
4	Drip tray. Install the pump on a small stand to prevent the ventilation holes from being flooded.
5	Mains water pipe

1.3.2 Suction from a well

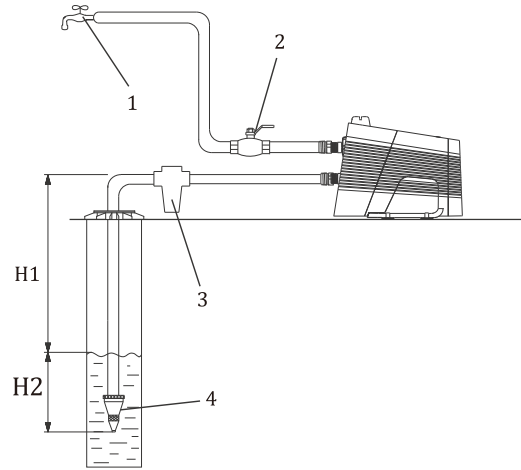

Suction from a well

Pos.	Description
1	Highest tapping point
2	Ball valve
3	Inlet filter. If the water may contain sand, gravel or other debris, please install a filter on the inlet side to protect the pump and installation.
4	Foot valve with strainer (recommended).
H1	Maximum suction lift is 8 m (26 ft).
H2	Inlet pipe must be submersed at least 0.5 m (1.64 ft).

1.3.3 Suction from freshwater tank

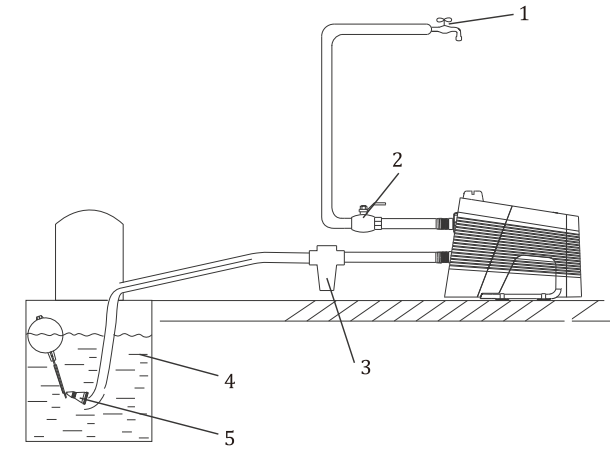

Suction from freshwater tank

Pos.	Description
1	Highest tapping point
2	Ball Valve
3	Inlet filter. If the water may contain sand, gravel or other debris, please install a filter on the inlet side to protect the pump and installation.
4	Freshwater tank
5	Foot valve with strainer (recommended)

2. Starting up the product



Do not start the pump until it has been filled with water.

2.1 Priming the pump

1. Unscrew the priming plug and pour minimum 1.2 litres (0.317 gallons) of water into the pump housing.



Priming the pump

2.2 Starting the pump

1. Open a tap to prepare the pump for venting.
2. Insert the power plug into the socket or turn on the power supply and the pump will start.
3. When water flows without air, close the tap.
4. Open the highest tapping point in the installation, preferably a shower.
5. Adjust the pressure set point to the required pressure by means of the buttons.
6. Close the tapping point.

2.3 How to set the correct pressure

The pump can be set to provide a water pressure between 1.0 to 5.5 bar (14.5 to 80 psi) at intervals of 0.5 bar (7 psi).

The factory setting is 3 bar (44 psi).

We recommend to use the default pressure of 3.0 bar (44 psi) which will suit most applications.

The difference between the inlet pressure and outlet pressure must not exceed 3.5 bar (51 psi).

Example: If the inlet pressure is 0.5 bar (7psi), the maximum outlet pressure is 4 bar(58 psi).

If you set the pressure too high, this might cause the pump to operate for up to three minutes after the tap is turned off.

2.3.1 Boosting from a well or a tank

If you are boosting from a well or a tank, make sure not to set the pressure setpoint too high.

The difference between the inlet pressure and outlet pressure must not exceed 3.5 bar (51 psi).

Maximum setpoint	[bar (psi)]
Well application	3.0 (44)
Tank below ground level	3.5 (51)
Tank above ground level	4.0 (58)

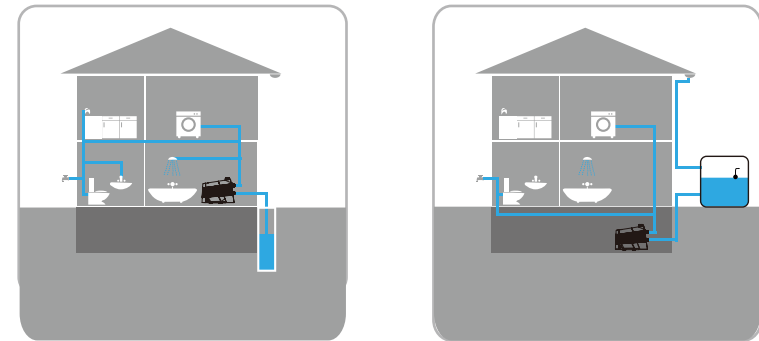

Boosting from a well or a tank

2.3.2 Boosting from the mains

The pressure settings 4.5, 5.0 and 5.5 bar (65, 73 and 80 psi) require a positive inlet pressure and these settings must only be used when boosting from the water mains.

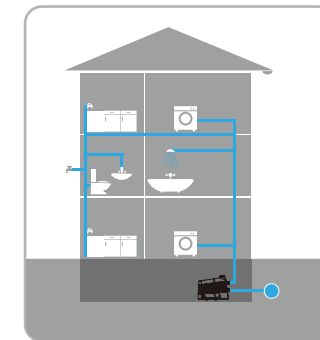

Boosting from the mains

3. Identification

3.1 Nameplate



Pos.	Description
1	Type designation
2	Approvals
3	Serial number
4	Voltage
5	Frequency
6	Rated power
7	Max. current
8	Maximum ambient temperature
9	Maximum liquid temperature
10	Maximum head
11	Maximum flow
12	Maximum liquid temperature
13	Maximum speed
14	Maximum Suction Head
15	Inlet&Outlet Diameter

4. Notice for use on the operating controlling panel.

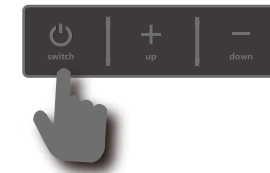

Press switch button shortly to start the pump while the power on, press the switch button shortly again to switch it off. The pump can be changed automatically from Auto mode to forced start mode by pressing the switch button for 8 seconds.

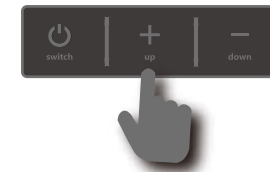

Full automatic mode: you may adjust the pump setting pressure by pressing the "+" or "-" button. Setting range from 1.5bar to 5.5bar (15m to 55m).

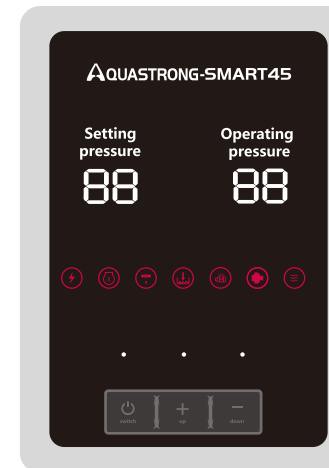

Setting pressure

88

Operating pressure

88

Automatic mode :

1. Setting pressure is the pressure what we stetterd for our piping line.
 2. Operating pressure is the pressure detected by sensor at outlet.
- Forced start mode : the motor rotation speed (rpm) shown on display.

4.1 1Duty&1Assistant Function Introduction

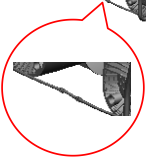
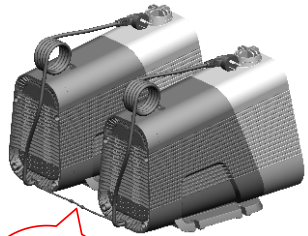

-1D&1A pump come with male head of data cable.
 -A additional date cable with both female head is required to connect two pumps.

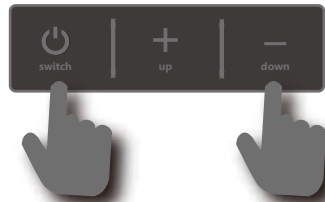

Set L2

-Long press the “power button” and “+ button” together to enter the setting menu.
 -Long press the “power button” and “+ button” again to switch to menu content.



Code	Defaults	Setting range	de?inition
L2	0	0/1	Duty pump and Assistant pump selection 0: setting as assistant pump 1: setting as Duty pump

Notice:

Mustn't set both pump as duty pump or assistant pump at the same time

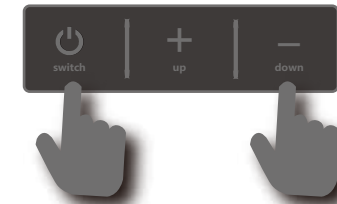

Set L1

-Long press the “power button” and “+ button” together to enter the setting menu.
 -Long press the “power button” and “+ button” again to switch to menu content.

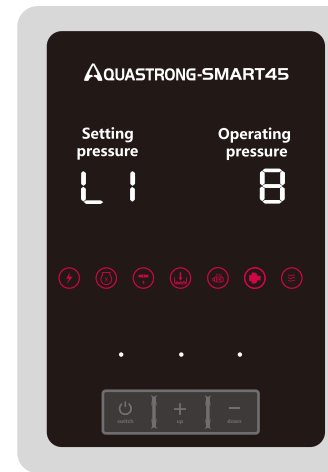

Code	Defaults	Setting range	de?inition
L1	8(hour)	0~48(hour)	Pump rotation setting: 0: two pumps work in rotation each time. 1~48: Two pumps work in rotation based on total working hours. (8hours means, the Duty pump works total 8hours,then the assistant pump work as Duty pump, Duty pump works as assistant pump. After 8hours, two pumps work in turn again)

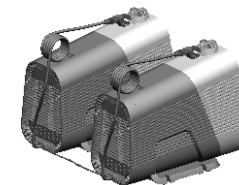

Warning

- 1.The PRESSURE SETTING NUMBER of Duty and Assistant pump must be same.
- 2.Avoid working directly exposure under the sun

5. Error report warning light instructions

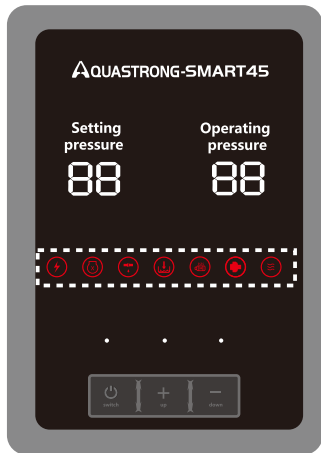

5.1 Power supply failure



Solution: Switch on the power supply. Check the cables and cable connections for defects and loose connections and check for blown fuses in the electrical installation.

5.2 The pump is blocked

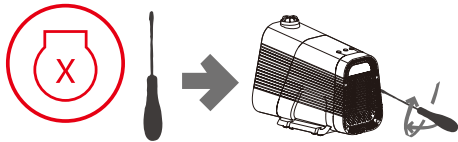

Solutions: Check whether there is some foreign matters in the pump, if yes, please take them out. And when the pump could work normally, the indicator light will turn off. Contact local authorized service center.

5.3 Pipeline leakage reminder:

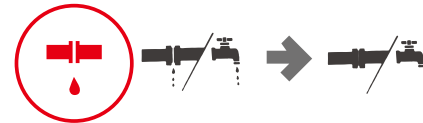

Solutions: Check whether there's any leakage in the pipeline or the tap, and repair the leakage.

5.4 Dry running or water shortage

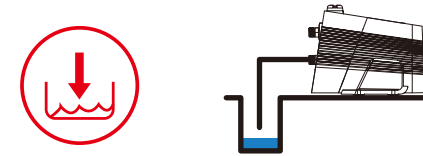

Solution: Check the water source, and prime the pump.

5.5 Overheating protection



Solution: Switch off the water pump, wait for the motor cooling down, and restart the water pump, this indicator light off. If no, contact local authorized service center.

5.6 Pressure sensor fault



Solution: fasten it if the pressure sensor is loose connections; replace it if the pressure sensor not loose connections. Restart the water pump, this indicator is off.

6. Taking the product out of operation

If the pump is taken out of operation for a period of time, for example during the winter, it must be disconnected from the power supply and placed in a dry location.

Proceed as follows:

1. Stop the pump by means of the on/off button.
2. Disconnect the power supply.
3. Open a tap to release the pressure in the pipe system.
4. Close the isolating valves and/or drain the pipes.
5. Gradually loosen the priming plug to release the pressure in the pump.
6. Remove the drain plug to drain the pump.
7. We recommend storing the pump indoors in a dry location. Due to humidity, the disconnected pump must not be left outside for a longer period of time.

7. Warranty of product

AQUASTRONG Co.,Ltd. offers 24 months of quality warranty for its products since the date of sales, and is responsible for product malfunctions or damaged due to manufacturing and material defects. This warranty is valid only when the product is installed strictly in accordance with AQUASTRONG installation and operation manual and certified operation practices.

This warranty is not applicable to product malfunctions or damage due to ① use in any other purpose other than that recommended by company; ② failure of compliance with AQUASTRONG installation and operation manual in the use of product; ③ inappropriate repair or moving of the product; ④ dismantling the product and/or replacing parts by themselves.

During the warranty period, the user can have the product repaired with purchase invoice and warranty card. Please deliver or send the product to your vendor or designated repair center of AQUASTRONG for repair. AQUASTRONG can decide whether to offer free home repair according to the local repair policies. The repair of parts and components within warranty period is free of charges.

AQUASTRONG Co.,Ltd. does not accept claims for damages due to third party liability or malfunctions caused by products of other companies.

AQUASTRONG Co.,Ltd. will not be liable for product malfunctions or damage due to abnormal operation conditions, war, riot, wind (rain) storm, disaster or other force majeure.

AQUASTRONG Co.,Ltd. reserves the right to interpret any matters unmentioned in this product warranty.

8. Easy worn parts



Pos.	Part
1	Pressure tank
2	Pressure sensor
3	Rear bearing 6202
4	Front bearing 6303
5	Mechanical seals